

ITEM NO.	PART NUMBER	MATERIAL	QTY.
1	SF2152	KOVAR	1
2	SP2152	KOVAR	2
3	SE2585	BO8	2

REVISIONS			
REV.	REVISED BY	DATE	DCN NO
2	J.BENNETT	05/06/2014	8931

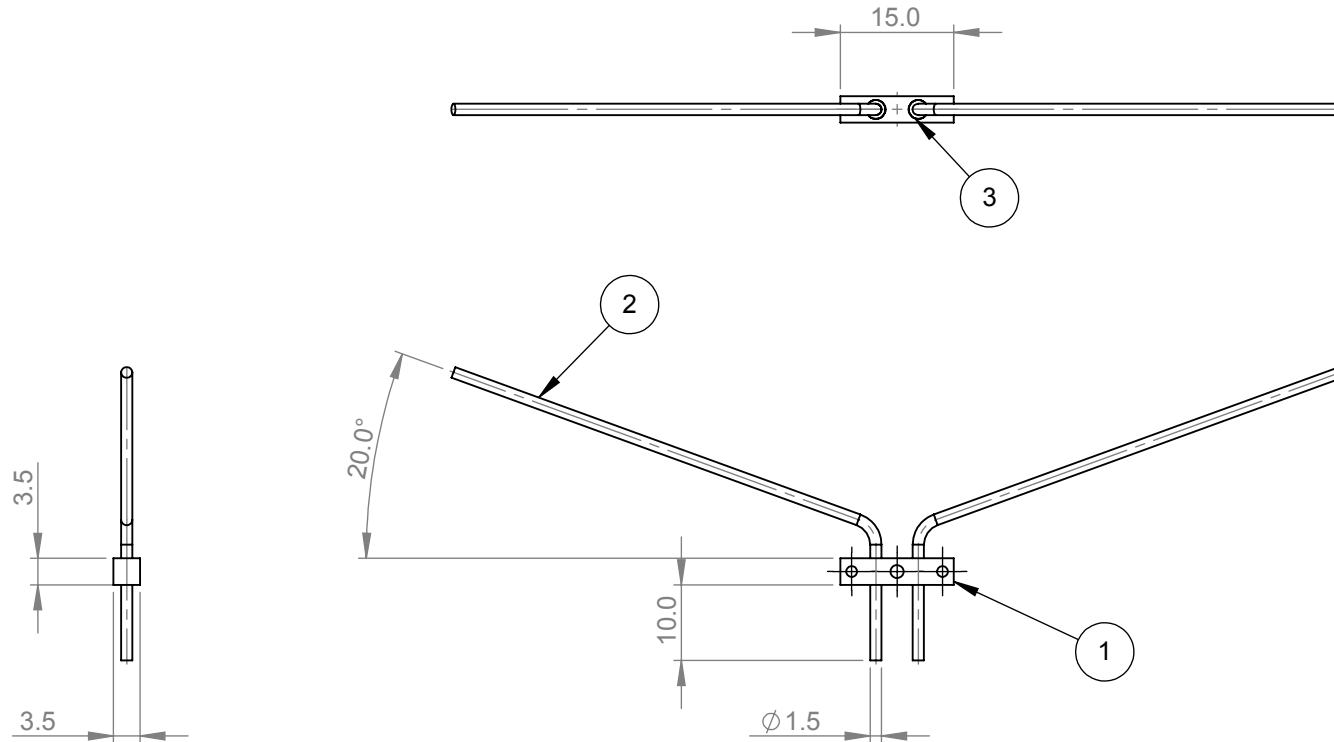

NOTES:

- 1) ITEMS MUST NOT EXHIBIT BURRS, SWARF, SCRATCHES, DENTS, DRAW MARKS, DAMAGE OR ANY DELETERIOUS MATERIAL.
- 2) ITEMS MUST BE PACKED TO AVOID DAMAGE OR DETERIORATION IN TRANSPORT OR STORAGE

MATERIAL: SEE BOM
MATERIAL CERTIFICATION REQUIRED

DO NOT SCALE DRAWING



enquiries@sgatech.co.uk

PROPRIETARY AND CONFIDENTIAL

THE INFORMATION CONTAINED IN THIS DRAWING IS THE SOLE PROPERTY OF **S.G.A TECHNOLOGIES LTD.** ANY REPRODUCTION IN PART OR AS A WHOLE WITHOUT WRITTEN PERMISSION OF **S.G.A TECHNOLOGIES LTD** IS PROHIBITED. ANY COPIES OF THIS DRAWING MADE BY ANY METHOD MUST INCLUDE A COPY OF THIS LEGEND AND THE **S.G.A** LOGO.

DRAWING STANDARD: THIS DRAWING COMPLIES TO BS EN ISO 1101:2005

UNLESS OTHERWISE SPECIFIED

DIMENSIONS ARE IN MILLIMETERS
TOLERANCES:-
LINEAR: ± 0.1
ANGULAR: $\pm 0.5^\circ$

SURFACE FINISH: $\sqrt{1.6}$

REMOVE ALL BURRS AND SHARP EDGES
INTERNAL/EXTERNAL CHAMFER $0.1 \times 45^\circ$ MAX
OR RADIUS R0.1 MAX

FINISH: SEE NOTES	
THIRD ANGLE PROJECTION	
NAME	DATE
DRAWN J.BENNETT	05/06/2014
APPV'D 8931	05/06/2014

TITLE: SEAL	
SIZE: A4	DWG NO. S2585
Location: J:\seals\2500-s2599\S2585_2	
WEIGHT: 0.46 g	SCALE: 1:1
SHEET 1 OF 1	