

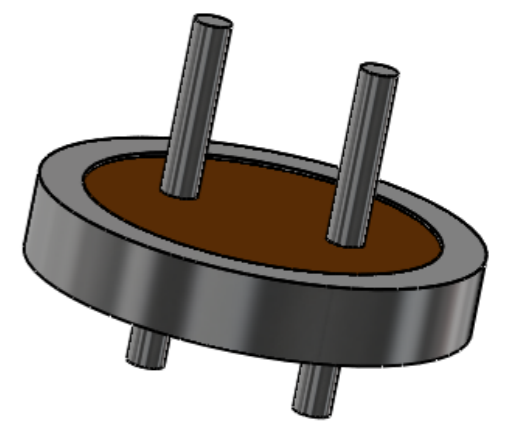

ITEM NO.	Dwg No	DESCRIPTION	MATERIAL	QTY.
1	SF3097A	Ferrule	KOVAR	1
2	SP3097A	Pin	KOVAR	2
3	SE3097A	Glass	Matched Expansion Glass	1

REVISIONS			
REV.	REVISED BY	DATE	DCN NO
1	Nigel Webb	19/09/2011	xxxx

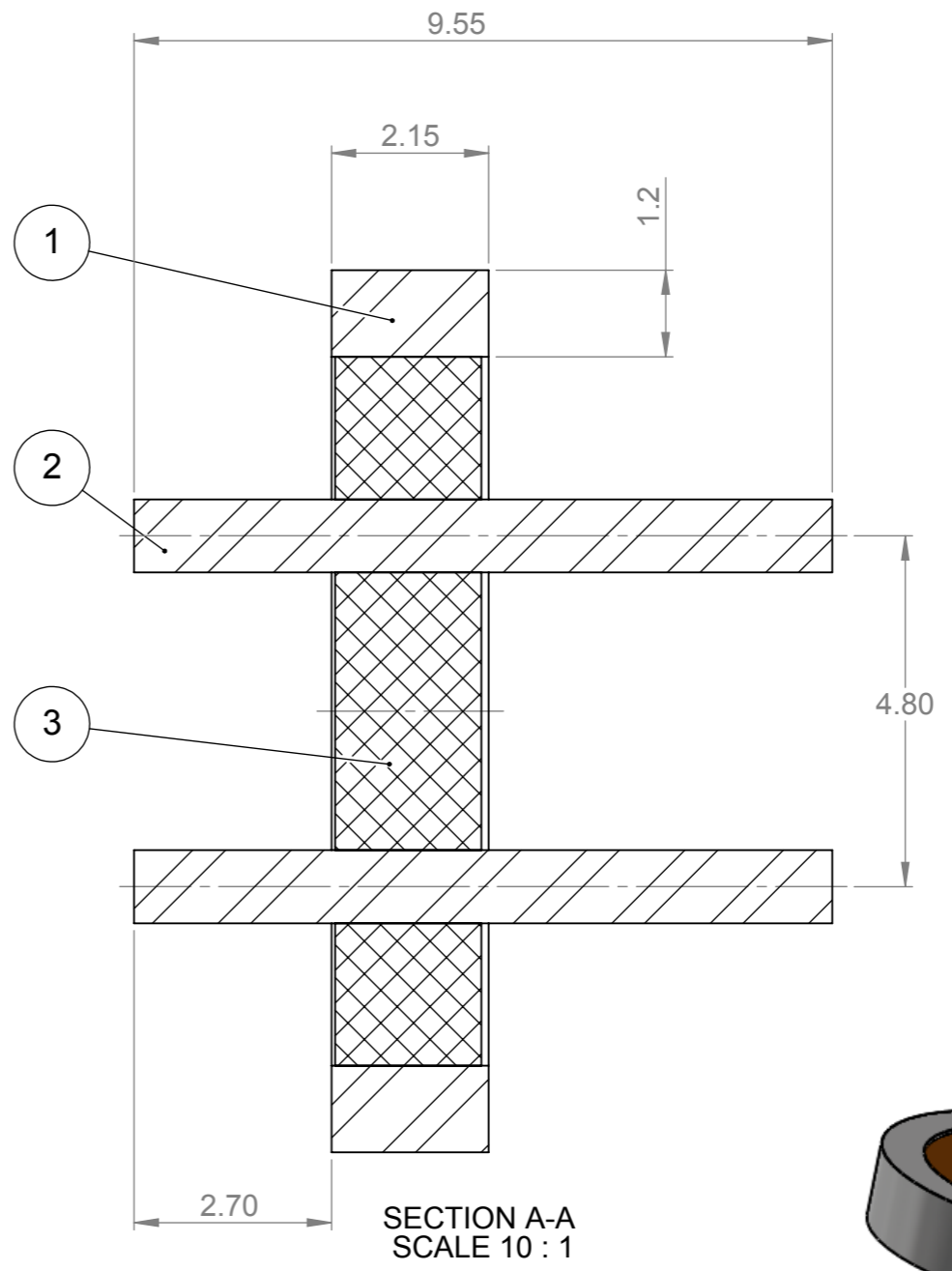
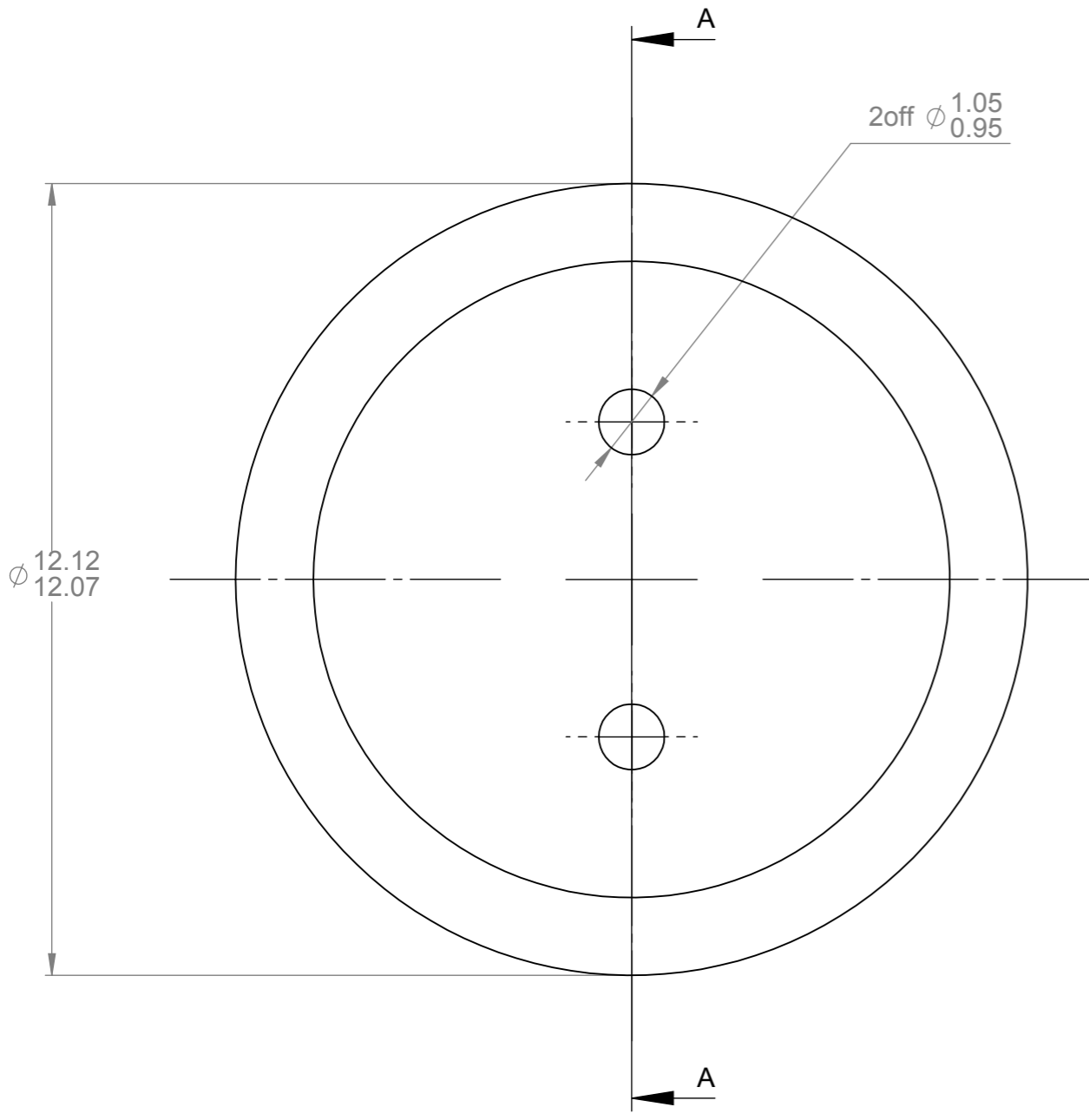

Finish
Clean & Bright, Unplated

DO NOT SCALE DRAWING



SGA technologies
enquiries@sgatech.co.uk

TITLE: GTMS	
SIZE: A3	DWG NO: S3097A
Location: E:\seals\S3000-S3099\s3097a_1	
WEIGHT: 1.24 g	SCALE: 5:1
SHEET 1 OF 1	

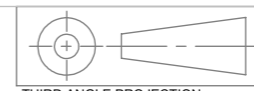
PROPRIETARY AND CONFIDENTIAL THE INFORMATION CONTAINED IN THIS DRAWING IS THE SOLE PROPERTY OF S.G.A TECHNOLOGIES LTD. ANY REPRODUCTION IN PART OR AS A WHOLE WITHOUT WRITTEN PERMISSION OF S.G.A TECHNOLOGIES LTD IS PROHIBITED. ANY COPIES OF THIS DRAWING MADE BY ANY METHOD MUST INCLUDE A COPY OF THIS LEGEND AND THE S.G.A LOGO.	UNLESS OTHERWISE SPECIFIED DIMENSIONS ARE IN MILLIMETERS TOLERANCES:- LINEAR: ± 0.1 ANGULAR: ± 0.5° SURFACE FINISH: $\sqrt{1.6}$ REMOVE ALL BURRS AND SHARP EDGES INTERNAL/EXTERNAL CHAMFER 0.1 x 45° MAX OR RADIUS R0.1 MAX	FINISH: Clean  THIRD ANGLE PROJECTION									
DRAWING STANDARD: THIS DRAWING COMPLIES TO BS EN ISO 1101:2005	<table border="1" style="width: 100%;"> <thead> <tr> <th>NAME</th> <th>DATE</th> </tr> </thead> <tbody> <tr> <td>DRAWN Nigel Webb</td> <td>19/09/2011</td> </tr> <tr> <td>APP'VD 384</td> <td>16/03/2012</td> </tr> </tbody> </table>	NAME	DATE	DRAWN Nigel Webb	19/09/2011	APP'VD 384	16/03/2012	<table border="1" style="width: 100%;"> <tr> <td>WEIGHT: 1.24 g</td> <td>SCALE: 5:1</td> <td>SHEET 1 OF 1</td> </tr> </table>	WEIGHT: 1.24 g	SCALE: 5:1	SHEET 1 OF 1
NAME	DATE										
DRAWN Nigel Webb	19/09/2011										
APP'VD 384	16/03/2012										
WEIGHT: 1.24 g	SCALE: 5:1	SHEET 1 OF 1									